

Best Solution for Every Exploration Drilling site.



HANJIN D&B
Drilling Equipments Co., Ltd.

Distributed by

- 49, Hanamsandan 10-Ro, Gwangsan-Gu, Gwangju, Republic of Korea
- TEL_ +82-62-953-4525 • FAX_ +82-62-953-4520
- E-mail_ mail@hanjindnb.com
- Website_ www.hanjindnb.com



Multi-Purpose Drilling Rig **D&B-30 Multi**

- Multi-Purpose drilling rig
(Diamond Core & Reverse Circulation drilling)
- Powerful drilling performance(N size : 1800m drilling)
- Top head Rotation system
- Auto Rod Changing System (Patent)



www.hanjindnb.com

Why D&B Exploration Drilling Rigs?

• World best quality products

Manufacturing high technology same as Water hammer, Sonic drill development.

• High technical Know-how

Producing more than 3000 rigs in the last 24 years

• Experience for Worldwide market

UK, Germany, Portugal, France, Italy, Czech, Slovakia, Greece, Romania, Kosovo, Hungary, Russia, Iraq, Qatar, Australia, New Zealand, Chile, Peru, Mexico, USA, Taiwan, Philippine, Indonesia, Malaysia, Singapore, HongKong, Mongolia, S Kazakhstan, South Africa, Congo, Mozambique, Sierra Leone, Tanzania, SUDAN, Ethiopia, Egypt, etc

• Management

Fast delivery time & Easy maintenance system

D&B's Other Products

R/C Hammer & Bits



- High drilling speed
- Long life time
- Special bit design

Sonic Drill



- Full hyd. system (Patent)
- Max. Vibration hammering (Max. 1800VPM)
- Constant amplitude

Water Hammer



- Deep hole drilling (5000m)
- Water pressure control system
- Water recycling system

Compressor/Double Compressor



- Less fuel consumption (Max. 10%)
- Special products for R/C drilling (Double compressor)

DTH Air Hammer



- Powerful drilling speed
- Low air consumption system
- Special HANJIN design

Rod Carrier



- Multi-Purpose transport car
- Max. climbing degree 30%
- Model : 7CR, 10CR, 15CR, 25CR
- Rod Loader (Option)

Drill Pipe

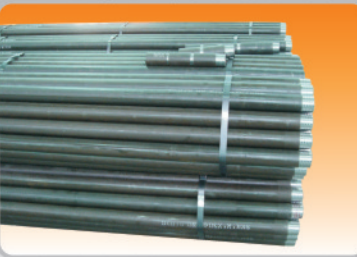

- R/C drill pipe
- Waterwell
- Core drill pipe (B, N, H, P size)

Mud Pump

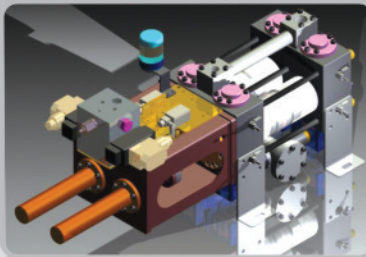

- Full hydraulic drive system
- Compact size design
- Model : 300, 800, 1200, 1500L

Multi-Purpose Drilling Rig D&B-30 Multi

1. Multi-purpose drilling rig (RC, Diamond, Non-core rotary, De-watering drilling, etc)
2. Powerful drilling
3. Top head rotation system
4. Unique Jib Crane : Useful angle drilling & casing handling.
5. Unique full hydraulic drive Mud pump (Variable volume control)
6. Reverse Circulation drilling : 400m drilling (5 inch)
7. Wire / Wireless Remote control system (Option)
8. Rod Loader / Easy drill pipe changing system (Option)
9. Truck mounted type is available (Option)

D&B-30 Multi Key Components

Mud Pump

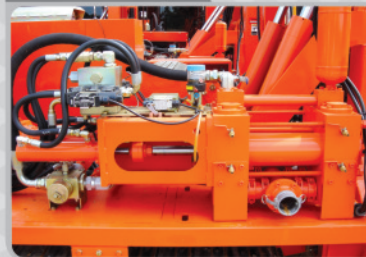

- Full Hydraulic drive system
- Unique D&B design & Made
- Variable volume control
- Low maintenance cost

Jib Crane



- Safe & easy operating
- Special D&B design & Made
- Powerful working

Rotary Head



- Strong rotation power
- Special D&B design & Made
- Top head rotation system
- Low maintenance cost
- Special air swivel design

Winch

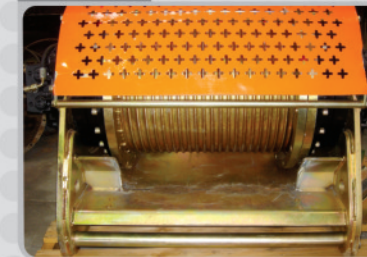

- Strong power
- Special D&B design & Made
- Speed control system

Self Loading Jack



- Crawler type only
- Special D&B design & Made
- Easy transport system

Remote Control (option)



- Wire/Wireless
- Easy & safe Drilling
- Safe Trammig

Rod Handler



- Convenience of work
- D&B's own technology
- Effective works

Wire Line

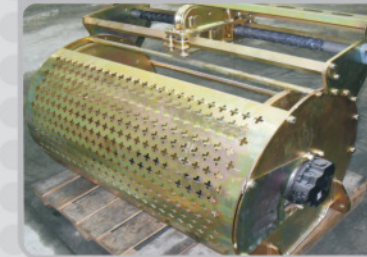

- Strong power
- Special D&B design & Made
- Speed control system

Worldwide Site

South Africa, Iron-ore mine



- D&B-30Multi
- RC drilling : 4 ½ inch, 150m

Australia, Kalgoorlie site



- D&B-30D
- Core/Soil sampling : P size 150m

Congo, Zanaga, Iron-ore mine



- D&B-30RC Special
- RC drilling : 4 ½ inch, 250m

Mozambique, Tete, Coal mine



- D&B-30Multi
- RC/Non-core drilling : H size(PDC bits), 500m

Kazakhstan, Almaty, Gold mine



- D&B-30Multi-TM
- RC drilling : 4 ½ inch, 350m

Chile



- D&B-30Multi-TM
- RC drilling : 4 ½ inch, 250m

Sierra Leone, Tonkolili, Iron-ore mine



- D&B-30Multi
- Diamond core drilling : N size 400-600m

Mongolia



- D&B-30Multi
- Diamond core drilling : P size 300m

Dimensions

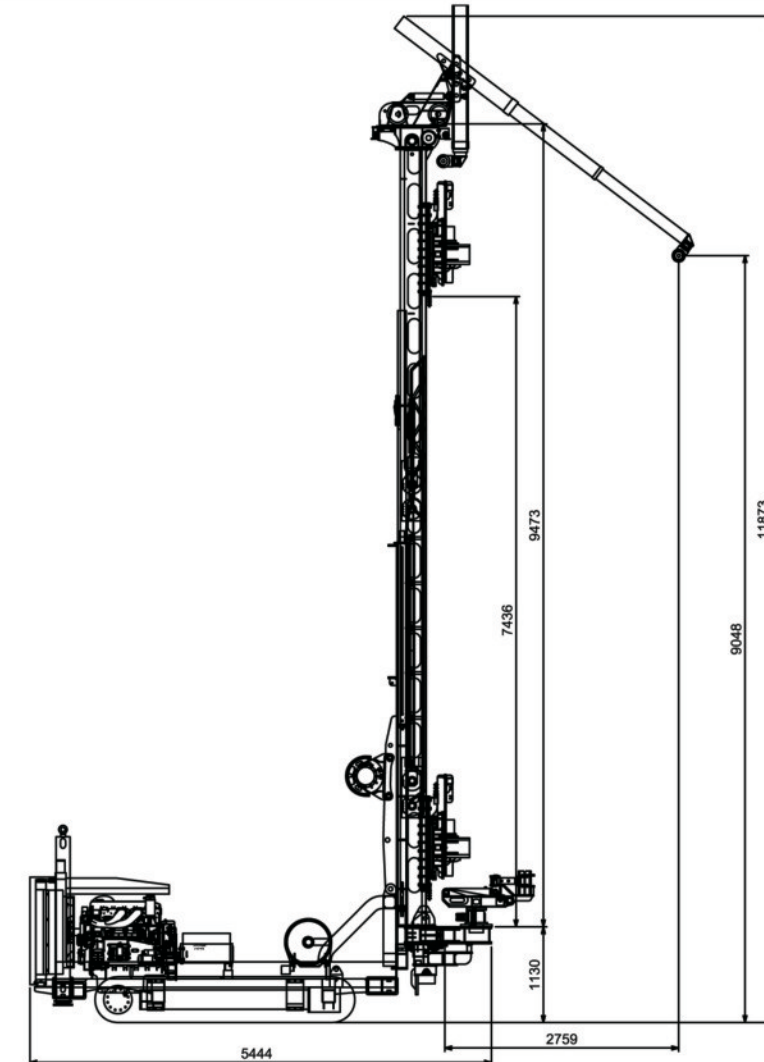

Transport Dimension

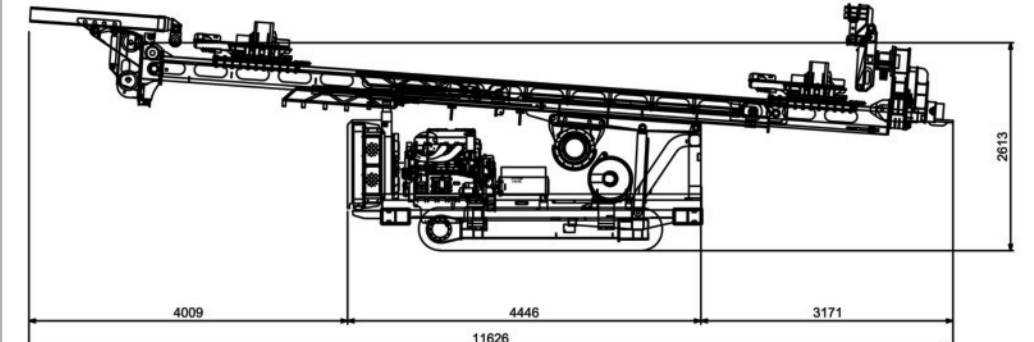
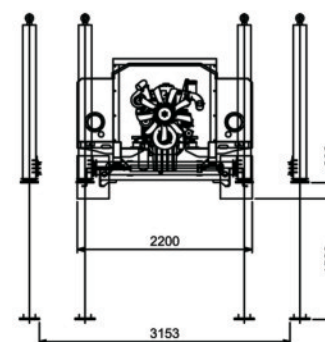

		D&B-30D	D&B-30 Multi
DIMENSIONS & WEIGHT			
OA length-transport	M	11.5	11.5
OA width	M	2.2	2.2
OA height-transport	M	2.6	2.6
OA height-mast up	M	11.5	11.5
Weight without drilling accessories	Ton	16	16
ENGINE			
Model(Diesel engine)		DOOSAN DL08/086Ti	DOOSAN DL08/086Ti
Cylinder		6	6
Rated power at 1800rpm	HP	285/280	285/280
Fuel capacity	ℓ	550	550
Cooling system		water cooling	water cooling
Rotary HEAD			
Model		Gearbox 900	Gearbox 900
Reduction		Super gear - 4.1 to 1	Super gear - 4.1 to 1
1st RPM/Torque	rpm/kNm.kg-m	1100~700 / 95~178	1100~700 / 95~178
2nd RPM/Torque	rpm/kNm.kg-m	636~450 / 150~280	636~450 / 150~280
3rd RPM/Torque	rpm/kNm.kg-m	470~327 / 205~390	470~327 / 205~390
4th RPM/Torque	rpm/kNm.kg-m	0~120 / 600~900	0~120 / 600~900
GEAR BOX Sliding			
Travel	mm	500	500
FEED SYSTEM			
Top head driven by hydraulic cylinders through heavy duty chain.			
Traverse cylinder	mmxmmxmm	160 x 100 x 3500	160 x 100 x 3500
Total length including extension (L*W*H)	mm	7000x3900x9100(7400)	7000x3900x9100(7400)
Max. Torque	kNm	30	30
Feed force	kN	250	250
Head travel (1st)	m	7.0	7.0
Dump mast / Up	m	1.5	1.5
Dump mast / Down	m	0.5	0.5
Pull-up capacity	ton/kN	30ton/300kN	30ton/300kN
Pull-down capacity	ton/kN	18ton/180kN	18ton/180kN
Feed speed-down (variable)	m/min	0~10	0~10
Fast feed speed-up (variable)	m/min	30	30
Fast feed speed-down (variable)	m/min	35	35
WORKING TABLE			
Max. casing diameter	inch	10	10
Hydraulic clamping			
Doubleclamp.Max Diameter (Standard version)	mm	280	280
Clamping size(Max)	mm	280	280
Clamping size(Min)	mm	73	73
Max.holding force	kN		
CRAWLER BASE			
Crawler type		Solar 55	Solar 55
Travelling speed	km/h	4	4
Ground pressure	N/cm ² , kg/cm ²	5, 0.5	5, 0.5
Shoes width	mm	400	400
Ground clearance	mm	400	400
Track shoes		3-web steel track shoes	3-web steel track shoes
Traction force	kN	70,000	70,000
Length of crawler units	mm	6480	6480
Climbing capacity Max.	%/degree	25°	25°
JIB			
Extension	mm	4200	4200
Loading Capacity	Max. Kgs	500	500
Turn	degree	60	60

		D&B-30D	D&B-30 Multi
SELF LOADING			
Ground clearance	mm	1400	1400
Width	mm	3100	3100
HYDRAULIC OUTRIGGER JACKS Four hydraulic outriggers are fitted to the outer corners of the rig for easy and accurate levelling of the rig.			
DRILL PIPE BREAKOUT			
Torque break-out	ton	4	4
WINCH			
Spool capacity		20M of 16mm cable	20M of 16mm cable
Line pull	ton	17	17
HYDRAULIC SYSTEM			
System		Load sensing/4pump open loop	Load sensing/4pump open loop
Hydraulic oil tank capacity	l	260	260
Filtration	micron	10	10
Pump model		K5V140x2+H3V63S+Pilot	K5V140x2+H3V63S+Pilot
Cooling system		Air cooling	Air cooling
Operating pressure	bar	280	280
Operating condition at job site	-30°~+45°	-30°~+45°	-30°~+45°
Flow rate 1st circuit	l/min		
Flow rate 2nd circuit	l/min		
Flow rate 3rd circuit	l/min		
Flow rate 4th circuit	l/min		
LIGHT & ELECTRICAL SYSTEM			
Mast	watt	2-60	2-60
Control panel		2-gauge floodlights	2-gauge floodlights
Work	watt	2-60	2-60
CONTROL PANEL All controls gauges are grouped at the operator's station within sight of the borehole.			
DRILL PIPE			
Max. Length	m	6	6
Max. Length(option)	m		
OPTION			
1. Mud Pump			
D&B-300MP	l/min	300	300
D&B-800MP	l/min	800	800
D&B-1200MP	l/min	1200	1200
D&B-1500MP	l/min	1500	1500
2. COMPRESSOR			
D&B-980CP	bar/cfm	X	X
D&B-1070CP	bar/cfm	X	X
3. Water Injection pump (High pressure washing pump)			
	l/min,bar	60/35	60/35
4. WELDER			
Hyd. Motor Drive		250 Amp.DC	250 Amp.DC
5. Rod handling system			
		X	X
6. Remote control for tramping			
		Wireless	Wireless
7. Dust collector			
		X	External
8. Cyclone			
		X	External
9. Rod rack			
		X	X
10. Remote control/Drilling			
		O	O
Drilling Performance			
P size drilling		~500	~500
H size drilling		~1000	~1000
N size drilling		~1800	~1800
B size drilling			
Notice			
1. Above drilling depth will be changed by job-site & working condition.			
2. All specification can be changed without any notice.			